

# CMM-K22F-OEM

The CMM-K22F-OEM is an industrial rated module featuring the MK22FN1M0VMD microcontroller. This small form factor (2.36" / 60mm x 3.94" / 100mm) board is ideal for low cost evaluation, development, and industrial OEM embedded application where higher signal counts and features are suitable.

## Target Applications:

- Industrial control
- Industrial networking
- HVAC systems/applications
- Human-machine interface (HMI)
- High-end lighting control
- Health care devices
- Fire and alarm systems/applications
- Security panels
- Internet controlled device

## FEATURES with Module support:

- ◆ MK22FN1M0 ARM Cortex-M4 MCU, 144BGA Package
  - 32 bit w/ DSP Instruction support
  - 3 Internal clocks, 120Mhz operation
  - 1M Byte Program Flash
  - 128K Byte SRAM
  - USB 2.0 OTG Port
  - External Flex Bus
  - 6x UARTs, 3x SPI, 2x I2C Serial Ports
  - SDHC bus
  - I2S Bus
  - All GPIO with Interrupt Inputs
  - 4x PIT timers
  - 3x Flex Timers w/ PWM, Motor control
  - 2 x 16bit ADCs, 4x differential channels
  - 2 x 12bit ADCs multiple channels
  - 2 x 12bit DAC outputs
  - 5V tolerant I/O
- ◆ WiFi enabled with ESP module.
- ◆ uSDcard connector, up to 32G byte memory
- ◆ USB OTG connector, host or endpoint modes
- ◆ 2x User Push Switches
- ◆ 2x User LED indicators
- ◆ 8MHz Primary and 32Khz RTC External Oscillators
- ◆ SDA Development Interface w/ USB COM Port (UART0)
- ◆ MCU I/O Ports, 2 x 64 pins, 2mm, optional
- ◆ Arduino / Freescale Shield I/O connectors (Bottom)
- ◆ Grove I2C (2), AN, and I/O connectors.
- ◆ JTAG / SWD Port, mini -10 connection
- ◆ +5V to 28V input power supplies w/ indicator
- ◆ RTC Battery support, CR1632 battery
- ◆ Freescale SDK / MQX RTOS Board Support Packages
- ◆ Cables and Wall-Plug power optional

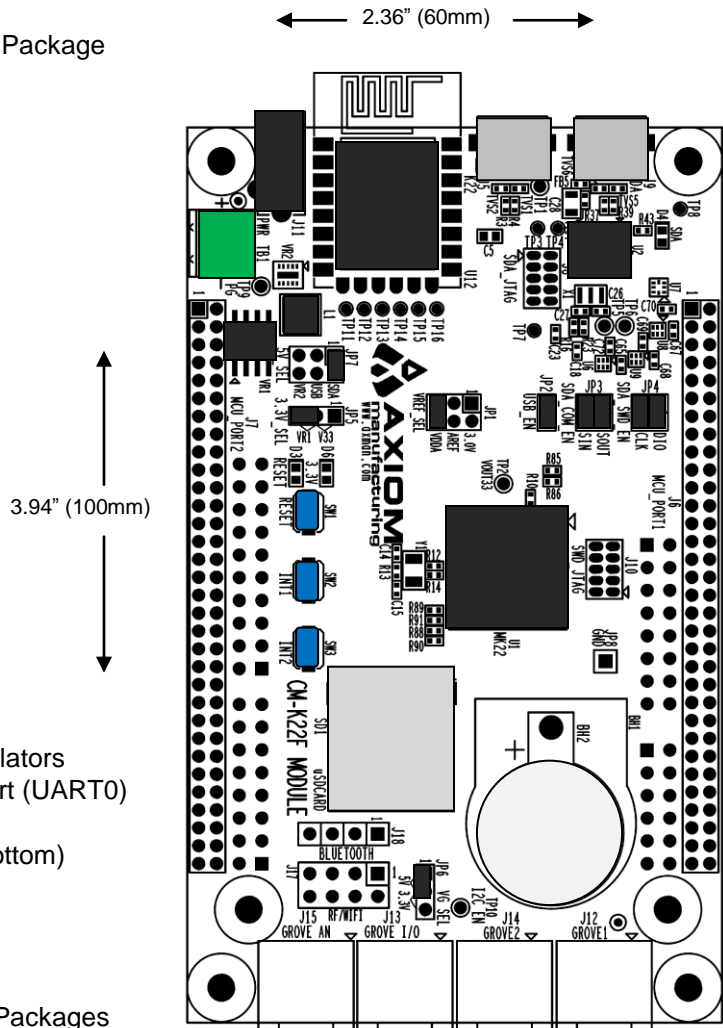

## Specifications:

Power Input: 1.3mm DC plug, Term Block, Stack, +4.75V to +28VDC.  
Board Size: 2.36W x 3.94L x 0.6 H Inches, .1" Mounting holes 2.0 x 3.75".

## Axiom Manufacturing

1226 Exchange Drive  
Richardson, TX 75081  
(972) 437-3737, FAX (972) 437-3736  
Internet: [www.axman.com](http://www.axman.com)  
[Sales@axman.com](mailto:Sales@axman.com)



# CMM-K22F-OEM

## Bottom Feature

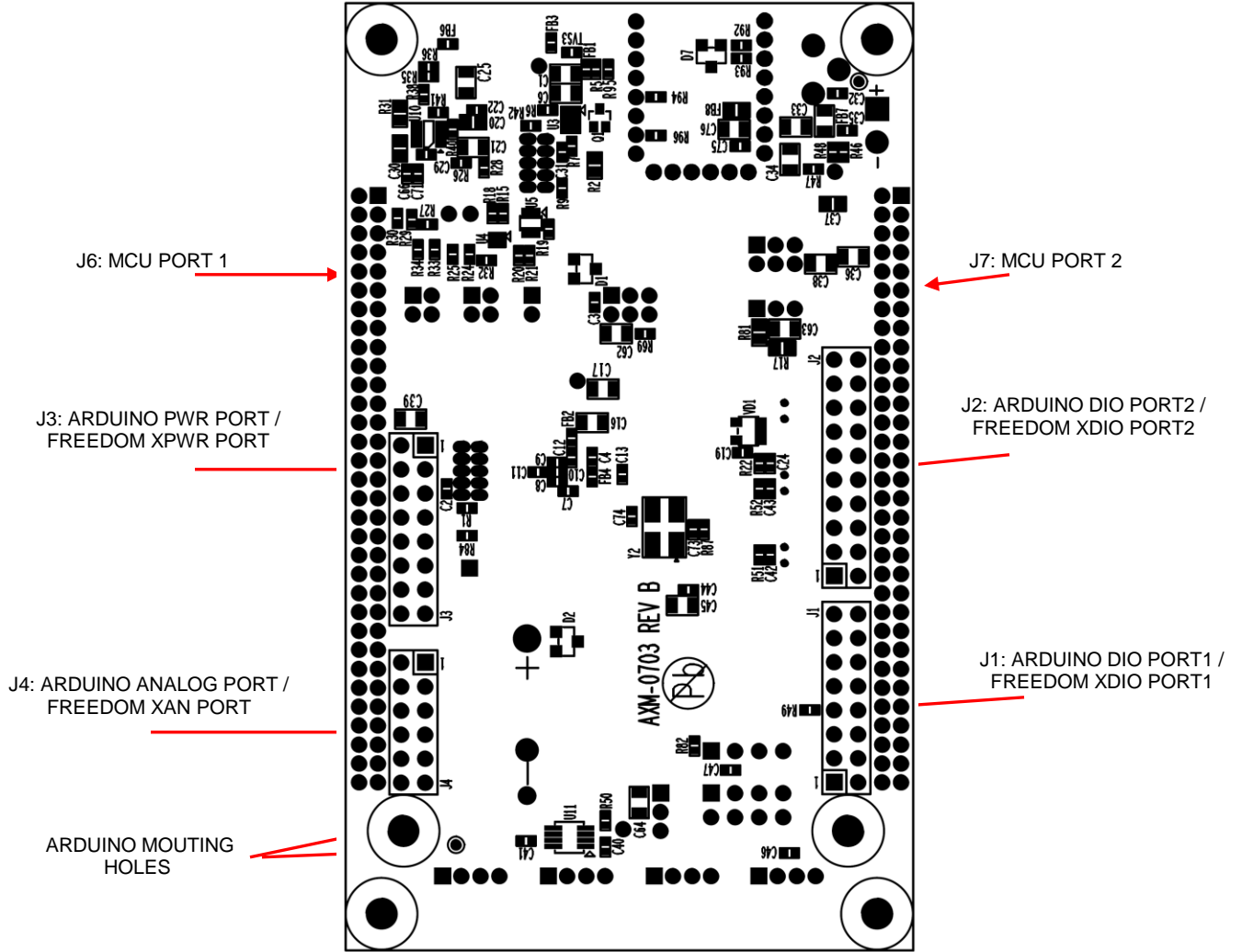

# CMM-K22F-OEM

## J1 and J2 Arduino / Freedom GPIO Connections

MCU PORT	K22 PORT	Arduino DIO	J1		Freedom XDIO	K22 PORT	MCU PORT
J6 – 23	PORT_C-16	DIO-0: RXD	2	1	XDIO-0: I2S_TX_BCLK	PORT_E-12	J7 – 23
J6 – 24	PORT_C-17	DIO-1: TXD	4	3	XDIO-1: I2S_TX_FS	PORT_E-11	J7 – 26
J7 – 57	PORT_A-7	DIO-2: INT/TMR	6	5	XDIO-2: I2S_TXD_0	PORT_E-10	J7 – 22
J7 – 58	PORT_A-8	DIO-3: INT/TMR	8	7	XDIO-3: I2S_MCLK	PORT_E-6	J7 – 19
J7 – 56	PORT_A-6	DIO-4: TMR	10	9	XDIO-4: I2S_RX_BCLK	PORT_E-9	J7 - 20
J7 - 49	PORT_A-9	DIO-5: TMR	12	11	XDIO-5: USB_SOF_OUT	PORT_C-7	J6 - 20
J6 – 53	PORT_B-10	DIO-6: AN/UART RX	14	13	XDIO-6: I2S_RX_FS	PORT_E-8	J7 - 21
J6 – 56	PORT_B-11	DIO-7: AN/UART TX	16	15	XDIO-7: I2S_RXD_0	PORT_E-7	J7 - 24

MCU PORT	K22 PORT	Arduino DIO	J2		Freedom XDIO	K22 PORT	MCU PORT
J7 – 54	PORT_A-10	DIO-8: TMR	2	1	XDIO-8: RTC_CLKOUT	PORT_E-26	
J7 – 51	PORT_A-11	DIO-9: TMR	4	3	XDIO-9: GROUND	GROUND	J7 - 18
J6 – 5	PORT_D-11	DIO-10: SPI_CS	6	5	XDIO-10: ADC0_0+	ADC0_DP0	J7 – 9
J6 - 9	PORT_D-13	DIO-11: SPI_SOUT	8	7	XDIO-11: ADC0_0-	ADC0_DM0	J7 – 10
J6 – 3	PORT_D-14	DIO-12: SPI_SIN	10	9	XDIO-12: SPARE		
J6 - 6	PORT_D-12	DIO-13: SPI_SCLK	12	11	XDIO-13: ADC1_0+	ADC1_DP0	J7 – 7
J6 - 18	GROUND	DIO-14: GROUND	14	13	XDIO-14: ADC1_0-	ADC1_DM0	J7 - 8
J7 - 16	VREFH	DIO-15: AREF	16	15	XDIO-15: SPARE		
J6 – 13**	PORT_D-9	DIO-16: I2C_SDA	18	17	XDIO-16: VREF_OUT	VREF_OUT	J7 - 12
J6 – 2**	PORT_D-8	DIO-17: I2C_SCL	20	19	XDIO-17: SPARE		

\*\* Also applied as I2C port for Grove connection at J12 and J14.

## J3 Arduino / Freedom Power Connection

MCU PORT	K22 PORT	Arduino PWR	J3		Freedom XPWR	K22 PORT	MCU PORT
		PWR-1: SPARE	2	1	XPWR-1: +VBAT		
J6 – 17	VDD	PWR -2: +3.3V	4	3	XPWR-2: VOUT33	VOUT33	
J6 – 39	RESET_B	PWR-3: RESET	6	5	XPWR-3: SPARE		
J7 - 17	VDD	PWR-4: +3.3V	8	7	XPWR-4: VDDA	VDDA	
J6 – 41	VREGIN	PWR-5: +5V	10	9	XPWR-5: SPARE		
J6 - 42	VSS	PWR-6: GROUND	12	11	XPWR-5: SPARE		
J6 - 64	VSS	PWR-7: GROUND	14	13	XPWR-5: SPARE		
J6 - 63		PWR-8: +VIN	16	15	XPWR-5: SPARE		

## J4 Arduino / Freedom Analog Connection

MCU PORT	K22 PORT	Arduino AN	J4		Freedom XAN	K22 PORT	MCU PORT
J6 – 59	PORT_B-6	AN_0: ADC1_SE12	2	1	XAN_0: ADC0_1+	ADC0_DP1	J7 – 4
J6 – 57	PORT_B-7	AN_1: ADC1_SE13	4	3	XAN_1: ADC0_1-	ADC0_DM1	J7 – 3
J6 – 61	PORT_B-4	AN_2: ADC1_SE10	6	5	XAN_2: ADC1_1+	ADC1_DP1	J7 – 6
J6 – 60	PORT_B-5	AN_3: ADC1_SE11	8	7	XAN_3: ADC1_1-	ADC1_DM1	J7 – 5
J6 - 58	PORT_B-3	AN_4: ADC0_SE13	10	9	XAN_4: CMP0_OUT	PORT_B-20	J6 – 45
J6 - 62	PORT_B-2	AN_5: ADC0_SE12	12	11	XAN_5: DAC0_OUT	ADC0_SE23	J7 - 14

# CMM-K22F-OEM

## J12 AND J14 GROVE I2C Connection

GROVE I2C	Signal	U3	U3	K22 PORT	Other Connect
J12 -1/ J14 - 1	I2C-SCL	8	5	PORT_D-8: I2C0_SCL	J2 and J6
J12 - 2 / J14 - 2	I2C-SDA	1	4	PORT_D-9: I2C0_SDA	J2 and J6
J12 -3/ J14 - 3	+V_Grove (JP6 setting)	7	3	+3.3V VDD	
J12 - 4 / J14 - 4	Ground	2	2	Ground	
TP10 (ground to disable U3 I2C out)	Grove I2C OE	6			

### Notes:

- 1) GROVE I2C signals are buffered by IC U3. TP10 provides U3 disable control.
- 2) JP6 provides Grove I2C / J12/ J14 voltage level setting of 3.3V or 5V(default).

## J13 Grove I/O Connection

GROVE I/O	Signal	K22 PORT	Other Connect
J13 - 1	I/O 1	PORT_E-28: GPIO	J7
J13 - 2	I/O 2	PORT_E-27: GPIO	J7
J13 - 3	3.3V IO	+3.3V VDD	
J13 - 4	Ground	Ground	

## J15 Grove Analog Connection

GROVE I/O	Signal	K22 PORT	Other Connect
J15 - 1	AN-1	PORT_E-25: ADC0_SE18, GPIO, UART4-RX	J7
J15 - 2	AN-2	PORT_E-24: ADC0_SE17, GPIO, UART4-TX	J7
J15 - 3	3.3V AN	+3.3V VDD	
J15 - 4	Ground	Ground	

# CMM-K22F-OEM

## J6 MCU Port Connection

Other Connection	Signal	K22 Port	J6 Pin		K22 Port	Signal	Other Connection
	FB_CS0*	PTD1	1	2	PTD8	I2C_SCL, FB_A16	J2-20, DIO_17
J2-10, DIO_12	SPI_IN, FB_A22	PTD14	3	4	PTD15	SPI_CS1, FB_A23	J17-4, RF_CS
J2-6, DIO_10	SPI_CS0, FB_A19	PTD11	5	6	PTD12	SPI_SCK, FB_A20	J2-12, DIO_13
	FB_AD0	PTD6	7	8	PTD7		
J2-8, DIO_11	SPI_OUT, FB_A21	PTD13	9	10	PTD2	FB_AD4	FB_AD4
	FB_ALE	PTD0	11	12	PTD5	FB_AD1	FB_AD2
J2-18, DIO16	I2C_SDA, FB_A17	PTD9	13	14	PTD4	FB_AD2	FB_AD1
SD1 - 12	SDCARD_DET, FB_A18	PTD10	15	16	PTD3	FB_AD3	FB_AD0
+3.3V	+3.3V	VDD	17	18	GND	Ground	Ground
	FB_AD11	PTC4	19	20	PTC7	FB_AD8	J1-11, XDIO_5
	FB_AD7	PTC8	21	22	PTC18		
J1-2, DIO_0	UART3_RX	PTC16	23	24	PTC17	UART3_TX	J1-4, DIO_1
	FB_RW	PTC11	25	26	PTC12	UART4_RTS	
		PTC19	27	28	PTC15	UART4_RX	J18-4, RF / WLAN RX
J18-3, RF / WLAN TX	UART4_TX	PTC14	29	30	PTC13	UART4_CTS	
	FB_AD5	PTC10	31	32	PTC9	FB_AD6	
	FB_AD9	PTC6	33	34	PTC1	FB_AD13	
	CLKOUT	PTC3	35	36	PTC0	FB_AD14	
	FB_AD12	PTC2	37	38	PTC5	FB_AD10	
SDA, J10-10, J3-6	RESET*	RESET*	39	40	GND	Ground	Ground
+5V	+5V	VREGIN	41	42	GND	Ground	Ground
		PTB0	43	44	PTB1		
J4-9, XAN_4	CMP0_OUT	PTB20	45	46	PTB21		
SDA option JP3-1	UART0_RX	PTB16	47	48	PTB17	UART0_TX	SDA option JP3-2
		PTB9	49	50	PTB22		
	FB_AD15	PTB18	51	52	PTB23		
J1-14, DIO_6		PTB10	53	54	PTB19	FB_OE	
SW2	INT	PTB8	55	56	PTB11		J1-16, DIO_7
J4-4, AN_1	ADC1_SE13	PTB7	57	58	PTB3	ADC0_SE13	J4-10, AN_4
J4-2, AN_0	ADC1_SE12	PTB6	59	60	PTB5	ADC1_SE11	J4-8, AN_3
J4-6, AN_2	ADC1_SE10	PTB4	61	62	PTB2	ADC0_SE12	J4-12, AN_5
+VIN	+VIN		63	64		Ground	Ground

# CMM-K22F-OEM

## J7 MCU Port Connection

Other Connection	Signal	K22 Port	J7 Pin		K22 Port	Signal	Other Connection
		ADC0_SE21	1	2	ADC0_SE22		
J4-3	XAN_1	ADC0_DM1	3	4	ADC0_DP1	XAN_0	J4-1
J4-7	XAN_3	ADC1_DM1	5	6	ADC1_DP1	XAN_2	J4-5
J2-11	XDIO_13	ADC1_DP0	7	8	ADC1_DM0	XDIO_14	J2-13
J2-5	XDIO_10	ADC0_DP0	9	10	ADC0_DM0	XDIO_11	J2-7
		ADC1_SE23	11	12	VREF_OUT	XDIO_16	J2-17
		RTC_WAKEUP	13	14	DAC0_OUT	XAN_5	J4-11
	AGND	VSSA	15	16	VREF_HI		JP1-1,2,3
+3.3V	+3.3V	VDD	17	18	VSS	Ground	Ground
J1-7, XDIO_3	I2S0_MCLK	PTE6	19	20	PTE9	I2S0_RX_BCLK	J1-9, XDIO_4
J1-13, XDIO_13	I2S0_RX_FS	PTE8	21	22	PTE10	I2S0_TXD_0	J1-5, XDIO_2
J1-1, XDIO_0	I2S0_TX_BCLK	PTE12	23	24	PTE7	I2S0_RXD_0	J1-15, XDIO_7
		PTE28	25	26	PTE11	I2S0_TX_FS	J1-3, XDIO_1
	CAN1_TX	PTE24	27	28	PTE26	RTC_CLKOUT	J2-1, XDIO_8
	CAN1_RX	PTE25	29	30	PTE27		
SD1-7, DAT0	SDHC0_D0	PTE1	31	32	PTE0	SDHC0_D1	SD1-8, DAT1
SD1-3, CMD	SDHC0_CMD	PTE3	33	34	PTE2	SDHC0_DCLK	SD1-5, DCLK
SD1-2, DAT3	SDHC0_D3	PTE4	35	36	PTE5	SDHC0_D2	SD1-1, DAT2
+3.3V	+3.3V	VDD	37	38	VSS	Ground	Ground
		PTA15	39	40	X-PTA18	EXTAL0	R90 Open Isolated
		PTA17	41	42	PTA16		
		PTA14	43	44	PTA5		
		PTA12	45	46	PTA13		
SW1	NMI*	PTA4	47	48	PTA2	TDO	J10-6
J1-12	DIO_5	PTA9	49	50	PTA0	TCLK / SWD_CLK	SDA JP4-2, J10-4
J2-4	DIO_9	PTA11	51	52	PTA1	TDI	J10-8
SDA JP4-1, J10-2	TMS / SWD_DIO	PTA3	53	54	PTA10	DIO_8	J2-2
R91 Open Isolated	XTAL0	X-PTA19	55	56	PTA6	DIO_4	J1-10
J1-6	DIO_2	PTA7	57	58	PTA8	DIO_3	J1-8
J17-8	RF_IRQ / WLAN IRQ	PTA28	59	60	PTA27	GPIO	WLAN Program
		PTA24	61	62	PTA25		
J17-3	RF_CE / WLAN CE	PTA29	63	64	PTA26		

**Axiom Manufacturing**  
 1226 Exchange Drive  
 Richardson, TX 75081  
 (972) 437-3737, FAX (972) 437-3736  
 Internet: [www.axman.com](http://www.axman.com)  
[Sales@axman.com](mailto:Sales@axman.com)