

Approvals		Date	File	
Drawn	GLG	072811	TWR-PXS30 AXM-0560	
Checked	DSR	072811	Size	Document Number
Finish			C	DOC-0560-030
		Date:	Thursday, November 10, 2011	Sheet 1 of 6



TWR-PXS30 AXM-0560

DOC-0560-030

Thursday, November 10, 2011 Sheet 1 of 6

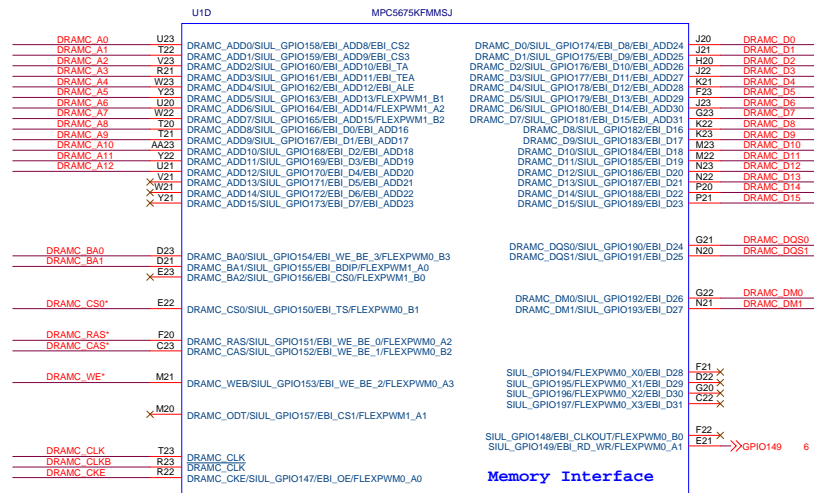

DDR

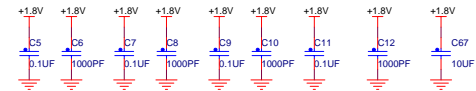

Approvals		Date	File	
Drawn	GLG	072811	TWR-PXS30 AXM-0560	
Checked	DSR	072811	Size	Doc Number
Finish			C	DOC-0560-030
Date: Thursday, November 10, 2011			Sheet	2 of 6

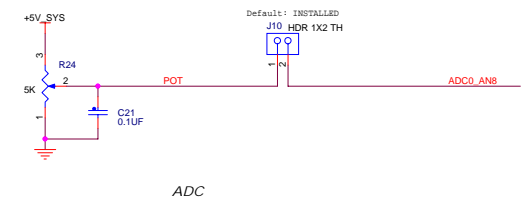
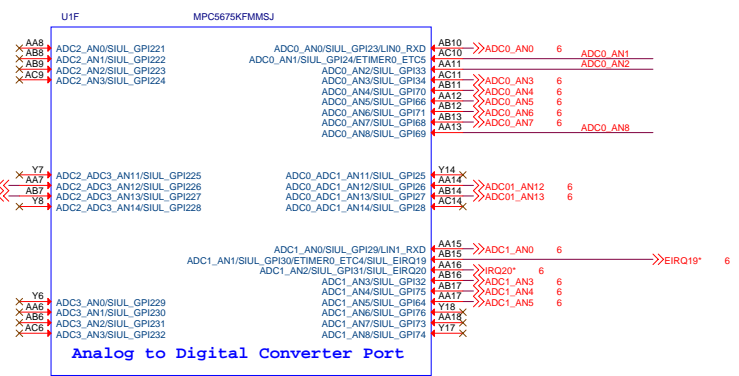
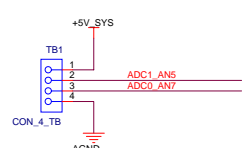
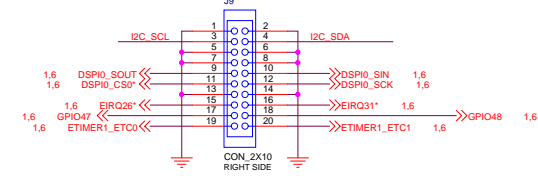
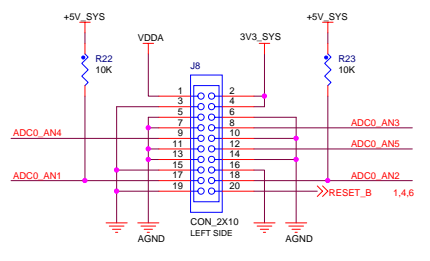
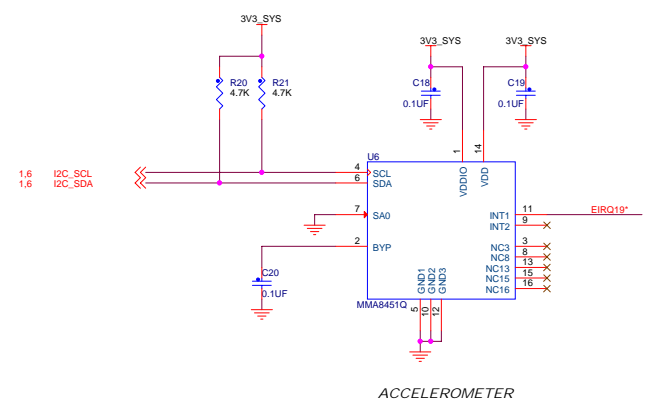
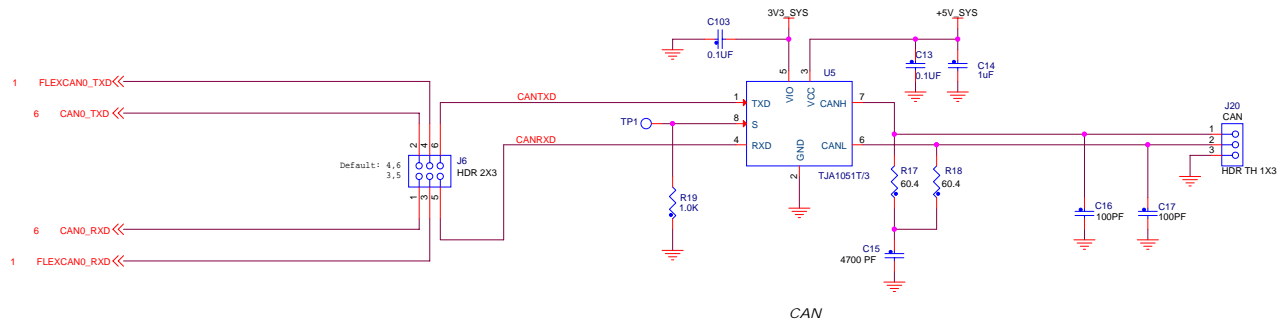

Approvals		Date	File	
Drawn	GLG	072811	TWR-PXS30 AXM-0560	
Checked	DSR	072811	Size	C
Finish			Document Number	DOC-0560-030
Date: Thursday, November 10, 2011			Sheet	3 of 6

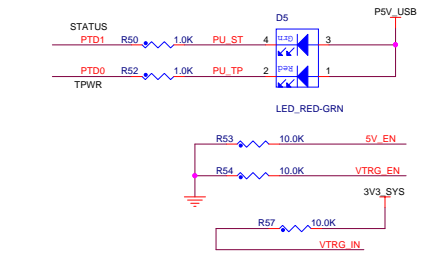
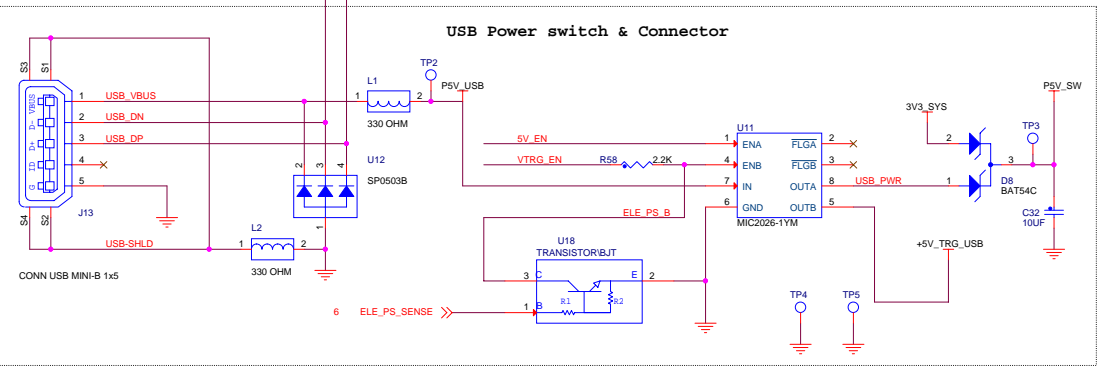
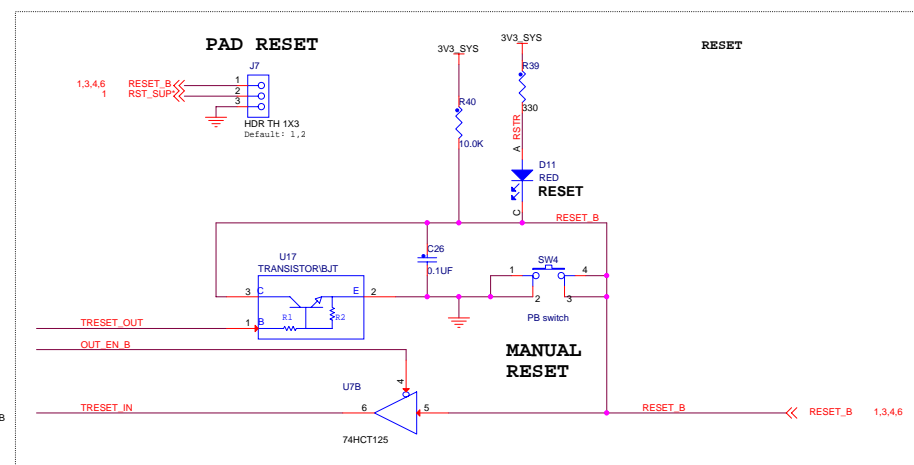
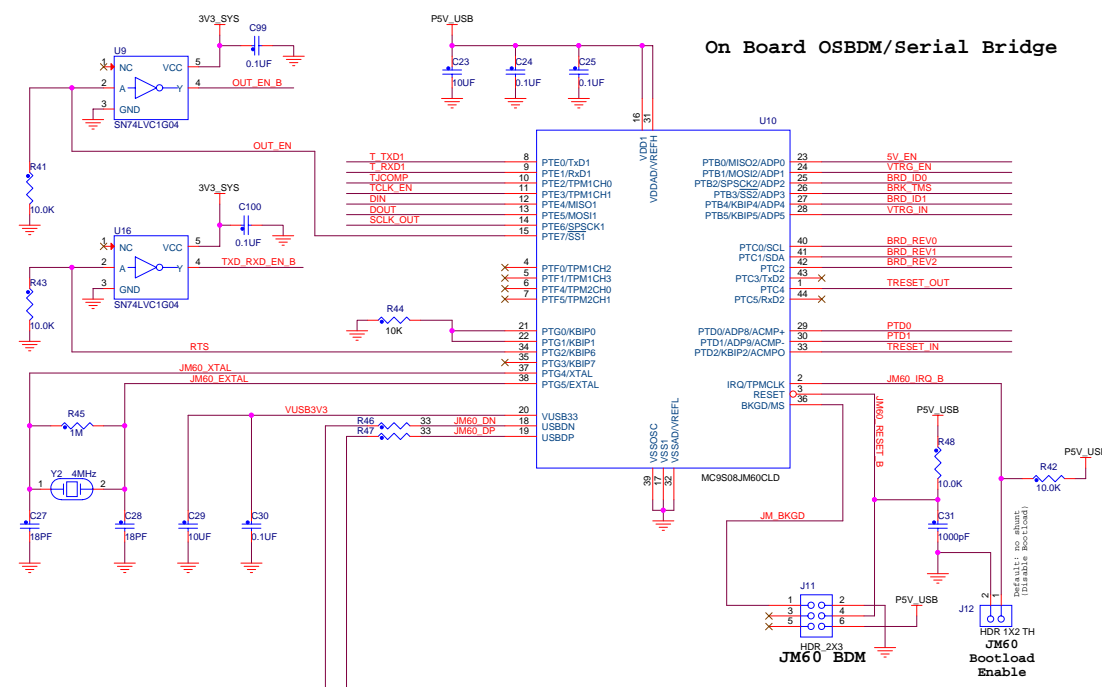
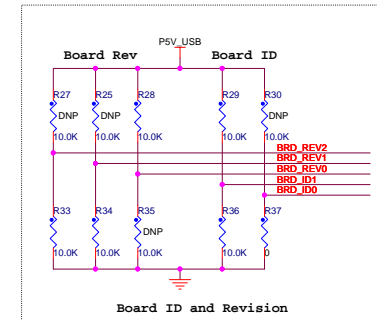
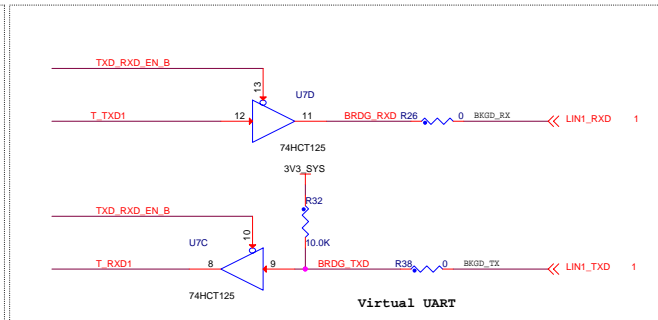
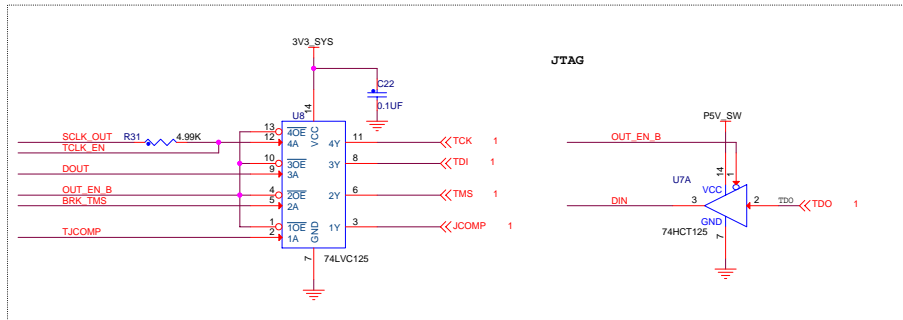

		File	
		TWR-PXS30 AXM-0560	
Drawn	GLG	Date	072811
Checked	DSR	Date	072811
Finish		Size	C
Date: Thursday, November 10, 2011		Document Number	DOC-0560-030
Sheet		4	of 6
			Rev B1

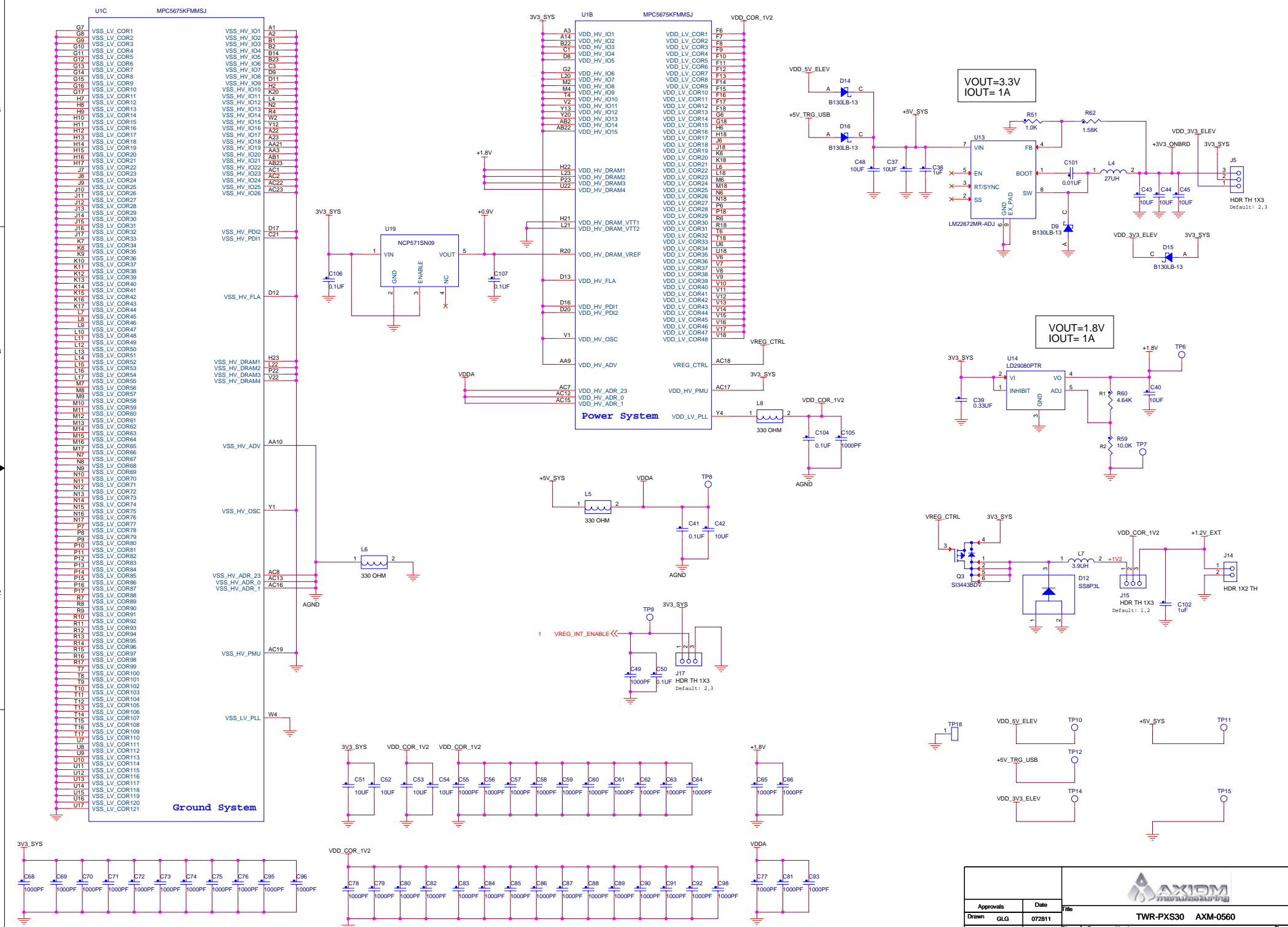

		File TWR-PXS30 AXM-0560	
		Document Number DOC-0560-030	Rev B1
Approvals Drawn: GLG Checked: DSR Finish:	Date 072811	Size C	Date Thursday, November 10, 2011
Sheet 5 of 6		Page 5 of 6	

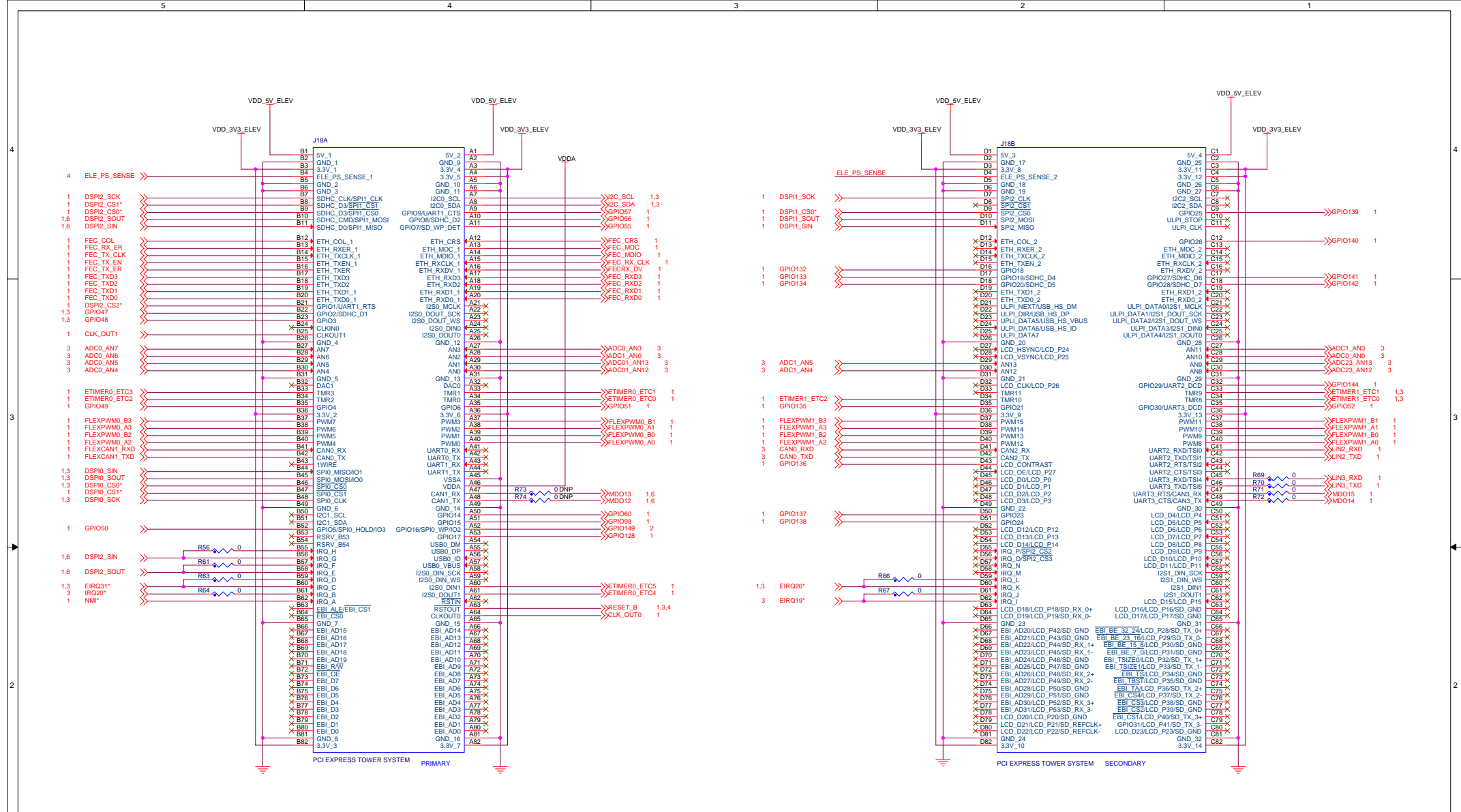

Approved	Date
Drawn	072811
Checked	DSR
Finish	
File TWR-PXS30 AXM-0560	
Size	Document Number
C	DOC-0560-030
Date:	Thursday, November 10, 2011
Sheet	6 of 6