

NOTES (UNLESS OTHERWISE SPECIFIED):
 1. ALL RESISTORS ARE 0603 SIZE, 5% TOLERANCE
 2. ALL RESISTOR NETWORKS ARE 0603X4.
 3. ALL CAPACITORS ARE 0603 SIZE, X7R.
 4. ALL CAPACITORS WITH VALUE 1000pF AND BELOW ARE NP0/COG, 5% TOLERANCE.
 5. ALL TESTPOINTS ARE 040 HOLE WITH 060 PAD.
 6. ALL JUMPERS ARE .100, VERTICAL.
 7. DEFAULT JUMPER SETTINGS ARE SHOWN.

		File	
		TWR-ADC DAC-AX	
Approved	GLM	Date	030113
Checked	DSR	Size	C
Finish		Document Number	DOC-0606-030
		Date:	Tuesday, March 12, 2013
		Sheet	1 of 2

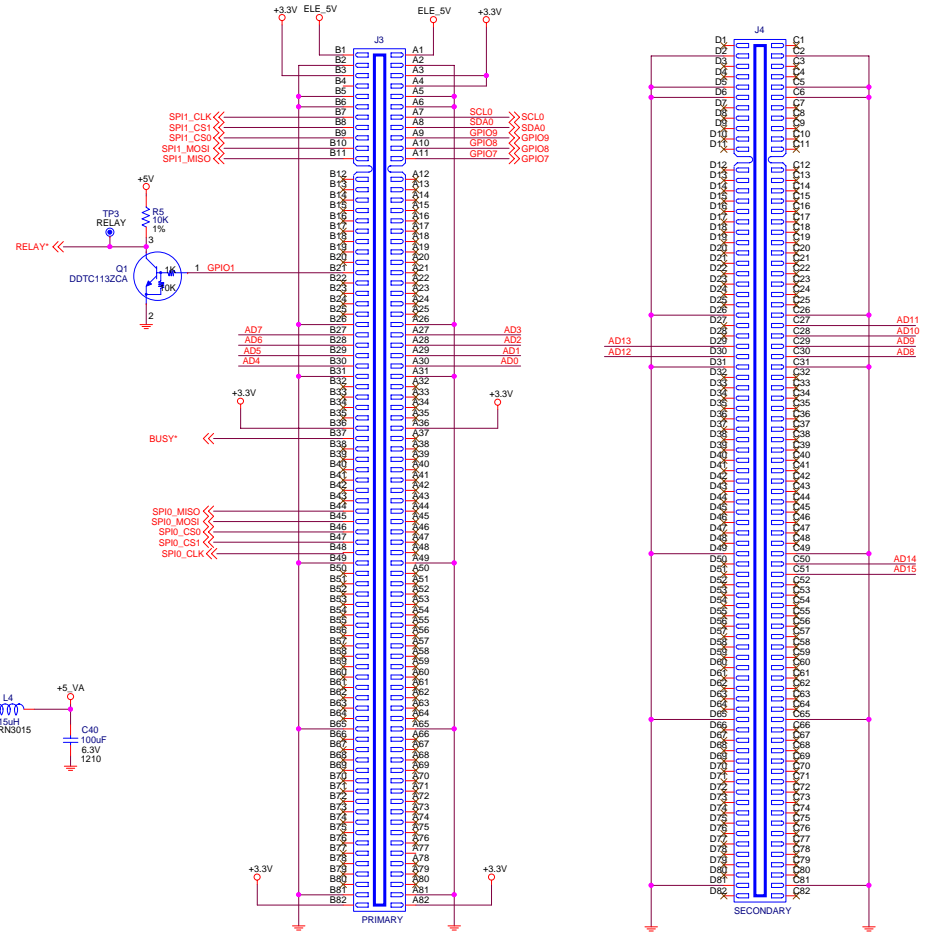

TOWER PCI EXPRESS SYSTEM

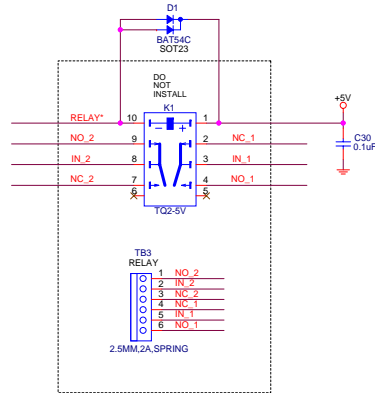
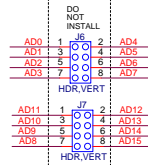
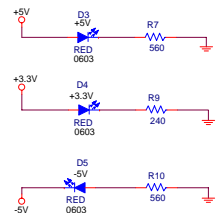
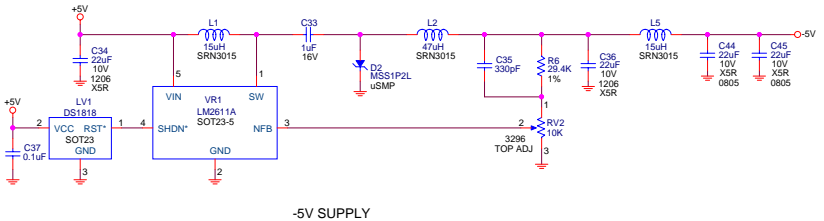
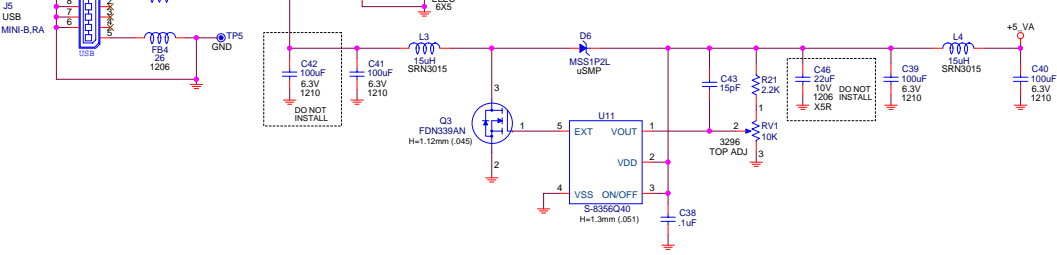

Approvals		Date	Title	
Drawn	GLM	030113	TWR-ABCDAC-AX	
Checked	DSR	030113	Size	Document Number
Finish			DOC-0606-030	Rev B
Date:		Tuesday, March 12, 2013	Sheet 2 of 2	

