

# MPC5553EVB

---

Development Board for the Freescale MPC5553

OPTIONS and CONNECTIONS

<b>CAUTIONARY NOTES</b> .....	<b>3</b>
<b>TERMINOLOGY</b> .....	<b>3</b>
<b>MPC5553EVB CONFIGURATION</b> .....	<b>4</b>
CONFIG SWITCH .....	4
SRAM_SEL OPTION .....	4
<b>POWER SUPPLY</b> .....	<b>5</b>
ON_OFF SWITCH .....	5
PWR - POWER JACK .....	5
FUUSE – F1 .....	5
POWER PORT .....	6
VSTBY SWITCH AND CT7 .....	6
ANALOG SUPPLIES .....	6
<b>USER COMPONENTS</b> .....	<b>7</b>
X1 CLOCK OSCILLATOR .....	7
RV1 AND RV2 USER POTENTIOMETERS .....	7
USER LED .....	7
USER SWITCH .....	7
USER_DEV .....	7
SW1 – SW4 PUSH SWITCHES .....	8
SPEAKER AND SPKR_VOL .....	8
<b>COMMUNICATION PORTS</b> .....	<b>8</b>
J1 - 10/100TX ETHERNET PORT .....	8
LNK, SPD, and ACT Indicators .....	9
J1 Ethernet Connector .....	9
COM-1 PORT .....	9
JP2 Option .....	9
CAN PORT .....	10
CAN_SEL Option .....	10
JP7 Option .....	11
LIN PORT .....	11
CT8 Option .....	11
JP3 Option .....	12
JP4 Option .....	12
JP5 Option .....	12
JP6 Option .....	12
LIN_PWR Option .....	12
LIN-J1 Connector .....	12
<b>UNI_3 MOTOR CONTROL PORT</b> .....	<b>13</b>
MOTOR_EN OPTION .....	13
HALL ENCODER PORT .....	13
UNI_3 PORT .....	14
RUN STOP SWITCH .....	14
RV4 FAULT ADJUST AND FAULT INDICATOR .....	14
SW3_UP AND SW4_DOWN .....	14
ETPU PORT .....	15
<b>DEVELOPMENT PORTS</b> .....	<b>15</b>
JTAG PORT .....	16
NEXUS PORT .....	16
ROBUST PORT .....	17
JP1 Option .....	17
<b>MPC5553 I/O HEADER RING</b> .....	<b>18</b>
A1 – AF4 HEADER .....	18
A22 – D5 HEADER .....	18
A23– AF26 HEADER .....	19
AC22– AF5 HEADER .....	19

# Cautionary Notes

- 1) Electrostatic Discharge (ESD) prevention measures should be applied whenever handling this product. ESD damage is not a warranty repair item.
- 2) Axiom Manufacturing reserves the right to make changes without further notice to any products to improve reliability, function or design. Axiom Manufacturing does not assume any liability arising out of the application or use of any product or circuit described herein; neither does it convey any license under patent rights or the rights of others.
- 3) EMC Information on the MPC5553EVB board:
  - a) This product as shipped from the factory with associated power supplies and cables, has been tested and meets with requirements of CE and the FCC as a **CLASS A** product.
  - b) This product is designed and intended for use as a development platform for hardware or software in an educational or professional laboratory.
  - c) In a domestic environment this product may cause radio interference in which case the user may be required to take adequate prevention measures.
  - d) Attaching additional wiring to this product or modifying the products operation from the factory default as shipped may effect its performance and also cause interference with other apparatus in the immediate vicinity. If such interference is detected, suitable mitigating measures should be taken.

## Terminology

This development board applies option selection jumpers. Terminology for application of the option jumpers is as follows:

Jumper on, in, or installed = jumper is a plastic shunt that fits across 2 pins and the shunt is installed so that the 2 pins are connected with the shunt.

Jumper off, out, or idle = jumper or shunt is installed so that only 1 pin holds the shunt, no 2 pins are connected, or jumper is removed. It is recommended that the jumpers be idled by installing on 1 pin so they will not be lost.

This development board applies hardwired option selections (VRL\_EN and CUTAWAY 1 – 16). These option selections apply a circuit trace between the option pads to complete a default connection. This type connection places an equivalent Jumper Installed type option. The circuit trace between the option pads maybe cut with a razor blade or similar type knife to isolate the default connection provided. Applying the default connection again can be performed by installing the option post pins and shunt jumper, or by applying a wire between the option pads.

# MPC5553EVB Configuration

## CONFIG Switch

The CONFIG switch provides reset configuration options for the MPC5553 device. Configuration options are enabled by position 1 of the switch. Switch positions 2 – 6 OFF provide an active low output condition to the respective configuration signal. Switch position ON will provide an active high signal condition.

POSITION	CONFIGURATION SIGNAL	DESCRIPTION
6	WKPCFG	<b>ON = default</b> , Refer to Freescale MPC5553 Documentation
5	PLLCFG1	<b>OFF = default</b> , Refer to Freescale MPC5553 Documentation
4	PLLCFG0	<b>ON = default</b> , Refer to Freescale MPC5553 Documentation
3	BOOTCFG1	<b>OFF = default</b> , Refer to Freescale MPC5553 Documentation
2	BOOTCFG0	<b>ON = default</b> , Refer to Freescale MPC5553 Documentation
1	CONFIG enable	<b>OFF= default</b> . ON = enables the RCON configuration to be applied from the switch settings.

## SRAM\_SEL Option

The MPC5553EVB board provides a 256K x 18 synchronous SRAM (U2) on the 16 bit data bus D0 – D15. SRAM data bits 16 and 17 are not applied. SRAM\_SEL provides selection of the CS0 or CS1 chip selects to access the external SRAM (U2) on the EVB board. Chip select configuration should be set for 0 wait states, 512K byte memory range, WE signals = Write Enable. The SRAM supports 4 word BURST mode access also.

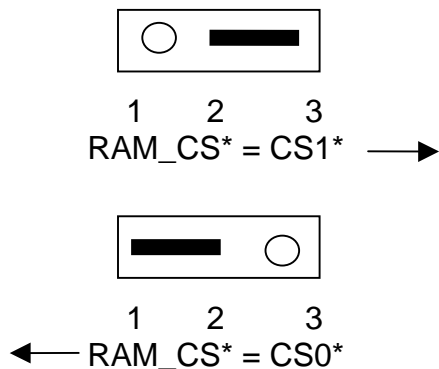

# POWER Supply

This section covers the MPC5553VB board power supplies and options. The primary power supply is the MC33730 device configured to support the MPC5553 device. The MPC5553 VRC regulator provides the VDD (1.5V) supply in the default configuration (CT1 and CT4 Open, CT2 and CT3 closed). MC33730 1.5V supply may be applied by optional configuration to provide the VDD 1.5V supply (CT1 and CT4 closed, CT2 and CT3 open).

Power supply Reset signals for the 5V, 1.5V and 3.3V supplies are applied to the MPC5553 RESET\* input by the closed S1 – S3 option pads respectfully. The open S0 option pad may apply the RSTKAM\* back-up supply reset signal if closed by the user. Also see the POWER\_PORT connection and MC33730 data sheet for power supply access details.

## ON\_OFF Switch

The ON\_OFF toggle switch provides ignition on and off control to the MC33730 supply. The MC33730 device will enable and disable the main power supplies. With the switch in the ON position, all power indicators should light. Inspect input power connection and source, and fuse F1 if power indication does not occur.

## PWR - Power Jack

The Power Jack provides the default power input to the board. The jack accepts a standard 2.0 ~ 2.1mm center barrel plug connector (positive voltage center) to provide the +VIN supply of +6 to +24 VDC (+12VDC typical).

+Volts, 2mm center

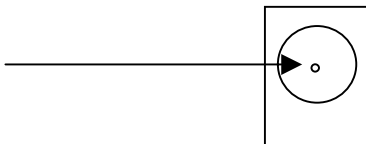

## FUSE – F1

Input power is limited by fuse F1. An 5x20mm type 1A slow-blow type fuse is applied to protect the EVB board for overload conditions.

## POWER Port

Power Port provides access to the main power supplies and MC33730 optional supplies. Note that the +VIN connection provided at pin 1 is not switched by the ON-OFF switch or fused and is directly connected to the Power Jack.

PIN #		SIGNAL DESCRIPTION
1	2	+V IN= DC input voltage from PWR jack (NO fuse or polarity protection).
3	4	+5V = regulated +5V supply from MC33730
5	6	+3.3V = regulated +3.3V supply from MC33730
7	8	+1.5V = regulated +1.5V supply from MC33730
9	10	VDD = MPC5553 VDD supply, 1.5V typically
11		VREF1 = MC33730 Optional 5V reference supply.
	12	+5VA = MC33730 VREF2 output dedicated to the MPC5553 5V analog supply.
13		RST3* = 3.3V power supply reset signal from MC33730 supply.
	14	VSTBY = 1V backup / standby voltage applied to MPC5553 VSTBY input. See VSTBY_SW and CT15 option also.
15		RSTL* = 1.5V power supply reset signal from MC33730 supply.
	16	REGON = control signal to the M33730, see MC33730 user guide.
17		RSTH* = 5V power supply reset signal from MC33730 supply.
	18	IGN_ON = control signal output from the MC33730, see MC33730 user guide.
19		RSTKAM* = Keep Alive / VSTBY / backup power supply reset signal from the MC33730.
	20	PFD = control signal output from the MC33730, see MC33730 user guide.
21	22	Ground / VSS

## VSTBY SWITCH and CT7

The VSTBY SWITCH provides enabling and disabling the VSTBY operation of the MPC5553 internal RAM. Switch in the OFF position disables the VSTBY operation and the VSTBY pin is connected to VSS / Ground. Switch in the ON position applies the +1VDC VKAM standby voltage from the MC33730 supply to the VSTBY pin.

Cut-away option CT7 allows the user to isolate the VSTBY pin of the MPC5553 from the switch. With CT7 open, the user must apply external battery or ground to the VSTBY position on the Power Port connector or I/O header ring.

## ANALOG Supplies

The MPC5553 VDDA supply (+5V default) is provided by the MC33730 VREF2 regulator output. VRH reference supply is provided by VDDA by default with the VRH\_EN option jumper installed. External VRH reference may be applied by removing the VRH\_EN option and applying reference voltage at header ring I/O pin A9. The VRL\_EN closed option pads connect the signal to common VSS supply by default. User may open this option to apply a precision ground to the VRL signal.

The QADC digital supply is provided +5V by option CT9. An optional connection to +3.3V for the QADC is provided by CT10. CT9 must be opened to install CT10 for +3.3V operation. See the MPC5553 user manual for more details on operating the QADC at +3.3V and limitations of the VDDA and VRH supplies.

# USER Components

The EVB board provides an External clock option (X1), 8 LED indicators, an 8 position DIP switch, 4 push switches, a speaker with amplifier, and 2 user potentiometers. These devices are accessed via the USER LED, USER SWITCH, and USER DEV I/O headers. EVB board user may apply the devices to the MPC5553 I/O header signals to evaluate operation or assist in code development.

## X1 CLOCK Oscillator

The X1 socket is provided to install standard 5V compatible CAN type clock oscillators so that alternate clock source or frequencies maybe applied to the MPC5553. User should refer to the MPC5553 device user manual for information on frequency selection and clocking configuration.

X1 clock signal is provided to the MPC5553 by option pad set CT6 being closed by 0 ohm resistor or mod wire application. CUT-AWAY option CT5 must be opened to remove the Y1 crystal from the EXTAL signal or problems may occur with operation. User should review the MPC5553 user guide for proper PLLCFG0 and PLLCFG1 (CONFIG Switch 4 and 5) option settings if an external clock is applied.

## RV1 and RV2 User Potentiometers

The User Potentiometers provide an adjustable linear voltage output from 0 to 5V. The voltage signal may be applied to an MPC5553 analog input port for user application.

## USER LED

User LED header provides access to the user LED 1 to 8. Connector pin 1 to 8 organization is provided in a one to one method to the individual indicators LED 1 to 8. The LED indicators are buffered for minimal drive current requirement (~300ua). Indicators will turn on with a logic high or 2.5 to 5V input at the respective connector pin.

## USER Switch

User Switch provides access to the user 8 position DIP Switch. Connector pin 1 to 8 organization is provided in a one to one organization to the individual DIP switch positions 1 to 8. The switch connections are pulled low with 10K ohm resistors when the switch position in the off position. Switch positions placed in the ON position will provide a 3.3V output to the connector.

## USER\_DEV

User DEV provides access to the 4 push switches (SW1 – SW4), speaker, and 2 user potentiometers (RV1 and RV2).

PIN #	USER COMPONENT CONNECTION
1	SW1 out, de-bounced CMOS drive 0 or 3.3V, active low.
2	SW1 out, de-bounced Open Drain output, active low, 10K ohm pull-up to 3.3V. Suitable for IRQ input signal drive.
3	SW2 out, active low, 10K ohm pull-up to 3.3V.
4	SW3 out, active low, 10K ohm pull-up to 3.3V.
5	SW4 out, active low, 10K ohm pull-up to 3.3V.
6	SPEAKER amp input. 0 to 5Vpp, volume adjust with SPKR_VOL.
7	RV1 center tap, 0 – 5V adjustment
8	RV2 center tap, 0 – 5V adjustment

## SW1 – SW4 Push Switches

The push switches provide momentary active low input for user applications. SW1 has additional features of being de-bounced for no glitch operation and push-pull output on pin 1 or open drain output on pin 2. Typical user application would be to provide program control or menu selection input.

SW3\_UP and SW4\_Down are also provided for the UNI\_3 Port motor control operation when the MOTOR\_EN option is installed.

## SPEAKER and SPKR\_VOL

The speaker and amplifier provide user applications with a method to generate sound effects from a MPC5553 output. Frequency range of the amplifier input is 300Hz to 10Khz. The SPKR\_VOL potentiometer allows user adjustment of the sound effect volume from the speaker. The amplifier also provides a SHDN input connection pad. This pad maybe connected to a MPC5553 output signal to disable the amplifier with a logic high signal of 3.3V or 5V.

## COMMUNICATION PORTS

### J1 - 10/100TX Ethernet Port

MPC5553 signals D16 – D31 are applied as the FEC module I/O port for Ethernet 10/100TX support provided at J1. FEC signals are applied to U11 (DP83848) 10/100TX PHY device. The J1 port provides AUTO MDIX cable connection detection for standard cross over or straight through type Ethernet CAT5E cables. Three Ethernet status indicators are provided for Link, Speed, and Activity.

The PHY device may also be included in the JTAG scan signals by options CT11, CT12, CT13, and CT15. Default configuration is PHY not included the scan, CT11 closed. To include the PHY in the JTAG scan CT11 should be opened, and CT12, CT13, and CT15 closed.



## *LNK, SPD, and ACT Indicators*

Ethernet status is provided by the LNK (Link status), SPD (10 or 100 speed status), and ACT (transmit status) indicators. All three indicators present Green for the active condition as follows:

**LNK** = ON for Ethernet network link detected. No link detected if off.

**SPD** = ON for 100TX operation. 10TX operation if off.

**ACT** = ON for MPC5553 transmit activity. Off indicates idle.

The status indicator operation can be modified by MAC PHY commands. Refer to the DP83848 and MPC5553 user manual for operation details.

## *J1 Ethernet Connector*

J1 provides the RJ45 style Ethernet 10/100TX port connection. The connector has an integrated transformer for network connection.

### **J1 connection**

Pin #	Signal
1	TX+
2	TX-
3	RX+
4	TX termination
5	TX Termination
6	RX-
7	RX Termination
8	RX Termination

## **COM-1 Port**

COM-1 is a standard RS232 type serial port configured for direct connection to a PC COM Port with a straight through type 9 pin serial cable. Option JP2 provides MPC5553 SCI channel 'A' signal connections when installed. Optional RTS and CTS hardware flow control connection pads are provided for the user to apply MPC5553 I/O ports and software to enhance operation.

### *JP2 Option*

The JP2 Option provides MPC5553 RXDA and TXDA signals to the COM1 transceiver connections. This allows the user to apply the provided communication transceiver with the SCI A channel or to apply the associated I/O to other purposes. JP2 position 1 installed enables the TXDA output and position 2 enables the RXDA input on COM-1.

**COM1 Connector**

1	1	X
TXD	2 6	6
RXD	3 7	CTS IN
4	4 8	RTS OUT
GND	5 9	9

The **COM-1** port is a Female (socket type) DB9 connector.

**Pins 1, 4, and 6 connected for status null to host.**

**Pins 7 and 8 maybe applied by CTS and RTS pads to MPC5553 I/O.**

RTS signal active output level is logic 0. User should place I/O port applied at logic low (0) to enable the RTS signal and reception of bytes if applied. User should apply a logic high signal under software control inform host or connected RS232 device to STOP transmitting (stop sending incoming bytes).

CTS signal active input is level is logic 0. User should apply software to detect a logic high signal or rising edge on applied I/O port and STOP transmitting bytes to the host or connected device to implement hardware flow control. Detection of a logic low input indicates the host is ready to receive bytes and the user may transmit.

DB9 connector pin locations are provided access pads behind the connector on the EVB board. User may isolate the connection pads by cutting the associated circuit trace on the bottom of the board.

**CAN Port**

The CAN Port provides 9 pin connector with a TJA1050 CAN transceiver interface to the MPC5553 CAN channels. The CAN\_SEL option locations select the CAN channel applied to the transceiver and CAN Port. User may apply more than one MPC5553 CAN channel to the port if the open drain TX output type is applied on the associated CAN channel transmit pins.

*CAN\_SEL Option*

The CAN\_SEL option header allows selection of the MPC5553 CAN channels applied to the transceiver and CAN Port. If more that one transmit channel is applied, transmit pins must apply the open drain output feature.

Note that the MPC5553 only provides CAN channels A and C, channel B support is provided for MPC5554 application.

POSITION #	MPC5553 CAN SIGNAL
1	CNTX_A, channel A TX out ( <b>DEFAULT enabled</b> )
2	CNRX_A, channel A RX in ( <b>DEFAULT enabled</b> )
3	CNTX_B, channel B TX out (N/A with MPC5553)
4	CNRX_B, channel B RX in (N/A with MPC5553)
5	CNTX_C, channel C TX out
6	CNRX_C, channel C RX in

## CAN\_PORT

1	1	X
CAN_LO	2 6	GND
GND	3 7	CAN_HI
4	4 8	8
5	5 9	9

**CAN** port has a Female (socket type) DB9 connector.

**CAN\_HI and CAN\_LO signals are terminated together with 120 ohms (R68).**

DB9 connector pin locations are provided access pads behind the connector on the EVB board for additional user application.

### JP7 Option

JP7 provides user option access to the CAN transceiver control input. Default option position of 1-2 selected provides normal CAN transceiver operation. User may option CAN transceiver for Transmit control by moving JP7 option jumper to positions 2-3 and applying a MPC5553 output pin to JP7 pin 1. Transmit disable operation is active high.

## LIN PORT

The LIN port provides a Master Mode LIN network connection. The MPC5553 device provides a LIN Master type node on the LIN Network. A LIN physical layer transceiver U7 (MC33661, or similar) is provided between the MPC5553 device and the LIN network connector. Refer to the MC33661 data sheet for complete details of transceiver operation. The following diagram represents the LIN connection:

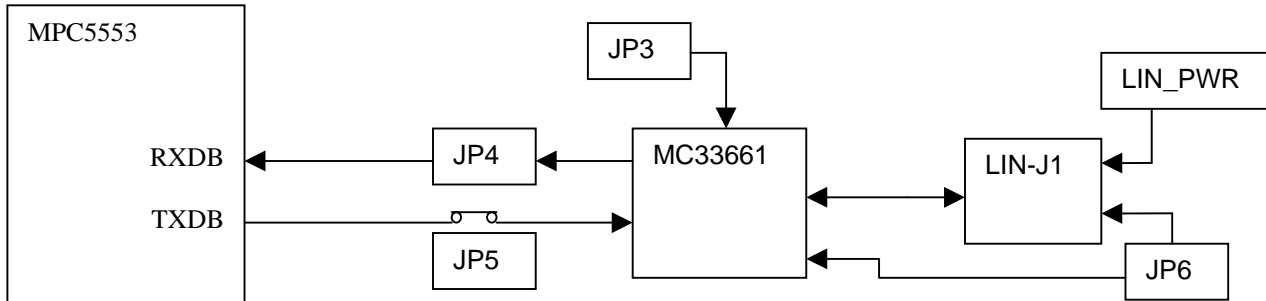

The LIN interface provides optional features of slew rate control, network supply, and wake up option. See the JP3, JP4, JP5, JP6, LIN\_PWR, and CT8 options following.

### CT8 Option

MPC5553 I/O signal GPIO205 provides LIN transceiver U7 enable control (EN pin). Software control of the EN pin allows the user to set the slew rate control of the transceiver. User applications should configure the GPIO205 pin for output to operate the LIN transceiver. If GPIO205 is needed for other purposes, the CT8 option maybe cut to isolate the signal from the LIN transceiver and JP3 installed to provide an enable to the transceiver. Refer to the MC33661 data sheet for further details of operation.

### *JP3 Option*

Installation of JP3 applies a pull-up resistor on the LIN transceiver enable pin. MPC5553 GPIO205 may still control the transceiver enable operation when JP3 is installed.

### *JP4 Option*

JP4 selects the MPC5553 SCI RXDB signal input to be from the LIN transceiver. For LIN operation JP4 must be installed.

### *JP5 Option*

JP5 is wired closed by default and not populated. JP5 provides the MPC5553 TXDB signal to the LIN transceiver. User may cut the JP5 wire trace to isolate the TXDB signal.

### *JP6 Option*

LIN-J1 connector pin 2 may be configured for different network requirements by JP6. JP6 open will disconnect LIN-J1 pin 2 from the EVB board.

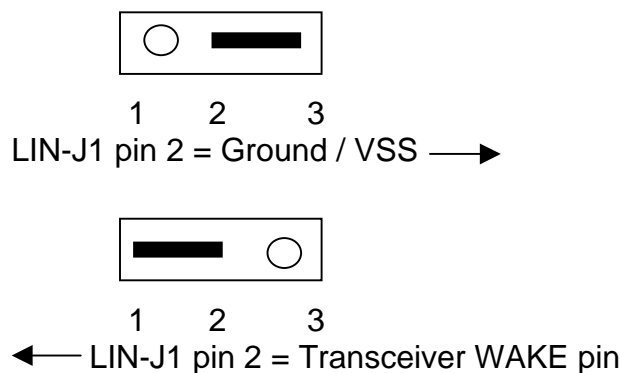

### *LIN\_PWR Option*

Installation of the LIN\_PWR option applies MPC5553EVB +V input voltage for LIN network power to LIN-J1 pin 3. This connection allows the EVB board to operate as a LIN master node to power remote LIN slave nodes. User should use caution to not overload the F1 fuse and verify only one source is applied on the network.

### *LIN-J1 Connector*

The LIN-J1 network connector provides a standard pin configuration with a network option position on pin 2.

**Front view** (looking into connector from outside of board edge)

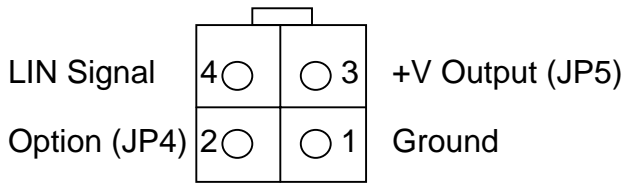

Mating connector = Molex 39-01-2040 with 39-00-0039 pins.

## UNI\_3 Motor Control Port

The UNI\_3 Motor Control Port is provided for easy application of the Freescale UNI\_3 Motor control application boards and motors. Many of the MPC5553 I/O signals are applied for the UNI\_3 motor control application so the user should review I/O application carefully. UNI\_3 port operation is enabled by the MOTOR\_EN option jumper installation.

## MOTOR\_EN Option

This option controls the connection of the MPC5553 I/O ports to the UNI\_3 and HALL\_ENCODER motor control ports. When installed, signal buffers U13 and U15 are enabled to apply MPC5553 I/O for motor control.

## HALL ENCODER Port

The Hall encoder port is provided for motor position feedback signals from the UNI\_3 motor application development boards.

HALL Port	HALL Signal	MPC5553 Signal
1	+5V	+5V / VDDH
2	GROUND	VSS / GROUND
3	H_1	eTPU_A1
4	H_2	eTPU_A2
5	H_3	eTPU_A3
6	H_4	eTPU_A4
x	H_CLK	TCRCLK_A, H_CLK is derived by logic from the H_1 – 4 signals.

## UNI\_3 Port

The UNI\_3 port is the primary motor control I/O port for application of the UNI\_3 motor control development boards. Following are the signal assignments:

MPC5553 Signal	UNI_3 Signal	UNI_3 Port		UNI_3 Signal	MPC5553 Signal
eTPU_A8	PWM_AT	1	2	Common 4,6,8,10	x
eTPU_A9	PWM_AB	3	4	Common 2,6,8,10	x
eTPU_A10	PWM_BT	5	6	Common 2,4,8,10	x
eTPU_A11	PWM_BB	7	8	Common 2,4,6,10	x
eTPU_A12	PWM_CT	9	10	Common 2,4,6,8	x
eTPU_A13	PWM_CB	11	12	GROUND	VSS / GROUND
VSS / GROUND	GROUND	13	14	x	
	x	15	16	x	
VSSA	ANALOG GND	17	18	ANALOG GND	VSSA
	x	19	20	x	
AN16	VS_DCB	21	22	IS_DCB	AN17
AN18	IS_A	23	24	ISB	AN19
AN20	IS_C	25	26	x	
	x	27	28	x	
eTPU_A15	BRAKE	29	30	x	
	x	31	32	x	
	x	33	34	ZX_A	eTPU_A5
eTPU_A6	ZX_B	35	36	ZX_C	eTPU_A7
	x	37	38	BEMF_A	AN21
AN22	BEMF_B	39	40	BEMF_C	AN23

## RUN STOP Switch

The RUN STOP switch is connected to the MPC5553 EMIOS11 signal pin. The switch provides a motor run or stop condition input for the motor control application.

## RV4 FAULT Adjust and Fault Indicator

RV4 Fault Adjustment is provided to set the applied motor over-current fault condition. The IS\_DCB current sense input from the UNI\_3 port is compared by U16 with the RV4 setting to determine if an over-current condition exists. If the IS\_DCB input signal is greater than the RV4 setting, the Fault condition becomes active. The FAULT indicator will light and an active low Fault signal will be provided to MPC5553 EMIOS10 signal pin.

## SW3\_UP and SW4\_Down

User switches SW3 and SW4 provide the motor speed UP and DOWN input signals when the MOTOR\_EN option is installed. Both switches are active low. SW3\_UP signal is provided to the MPC5553 EMIOS8 signal pin. SW4\_DOWN signal is provided to the MPC5553 EMIOS9 signal pin.

## eTPU Port

The eTPU\_PORT provides an organized I/O port for the MPC5553 eTPU\_A signals.

MPC5553 Signal	eTPU Port		MPC5553 Signal
+3.3V	1	2	+5V
eTPU_A16	3	4	x
eTPU_A17	5	6	x
eTPU_A18	7	8	eTPU_A0
eTPU_A19	9	10	eTPU_A1
eTPU_A20	11	12	eTPU_A2
eTPU_A21	13	14	eTPU_A3
eTPU_A22	15	16	eTPU_A4
eTPU_A23	17	18	eTPU_A5
eTPU_A24	19	20	eTPU_A6
eTPU_A25	21	22	eTPU_A7
eTPU_A26	23	24	eTPU_A8
eTPU_A27	25	26	eTPU_A9
eTPU_A28	27	28	eTPU_A10
eTPU_A29	29	30	eTPU_A11
eTPU_A30	31	32	eTPU_A12
eTPU_A31	33	34	eTPU_A13
GND	35	36	eTPU_A14
TCRCLK_A	37	38	eTPU_A15
GND	39	40	GND

## DEVELOPMENT PORTS

The MPC5553EVB board provides 1 JTAG and 2 NEXUS type development ports. Only one of the development ports should be applied due to common signals used on the ports. The development port input and power signals are buffered by a CBTLV3861 device. This buffer provides a bi-directional 5 ohms series resistance on the input signals when powered on. The buffer also provides signal isolation when powered off.

**NOTE: Proper power sequencing must be performed when a development port is applied (cable connected). Development port application power sequence:**

- 1) MPC5553EVB board ON-OFF switch is OFF and no power is applied to the PWR connector.
- 2) Connect development port cable to the desired MPC5553EVB board development port.
- 3) Apply power to the MPC5553EVB board PWR connector and turn ON-OFF switch ON.
- 4) If power is removed or the ON-OFF switch is turned off, remove development cable from board connector and re-apply from step 1 of this procedure.

## JTAG Port

The JTAG port provides a Freescale standard JTAG connection to the MPC5553. The connector is a standard 2x7, .1 inch pin space keyed pin header. Example compatible cables include the OCDEMON™ NP-JTAG ONCE “Wiggler” and the P&E Microcomputer Systems CABPPCNEXUS. Host software must be applied to operate the cables.

### JTAG Port

Signal	Pin #	Pin #	Signal
B_TDI	1	2	GND
TDO	3	4	GND
B-TCK	5	6	GND
B_EVTI*	7	8	JTG8 TP
B-RESET*	9	10	B_TMS
B_+3.3V	11	12	GND
B_RDY*	13	14	B_JCOMP

#### Notes:

- 1) B\_... signals are buffered.
- 2) JTGx TP signals are not connected to the MPC5553 and provide a Test Pad on the board.
- 3) Signals followed by a “\*” symbol are active logic low.
- 4) See the J1 Ethernet section about the PHY device and JTAG.

## NEXUS Port

The NEXUS port provides a more powerful and higher speed development port for high end tools. The port connector is an AMP 38 pin Mictor style, part number #767053-1.

### NEXUS Port

Signal	Pin #	Pin #	Signal
NXS1 TP	1	2	NXS2 TP
NXS3 TP	3	4	NXS4 TP
MDO9	5	6	CLKOUT
BOOTCFG1	7	8	MDO8
B_RESET*	9	10	B_EVTI*
TDO	11	12	B_+3.3V
MDO10	13	14	B_RDY*
B_TCK	15	16	MDO7
B_TMS	17	18	MDO6
B_TDI	19	20	MDO5
B_JCOMP	21	22	MDO4
MDO11	23	24	MDO3
ERSTOUT*	25	26	MDO2
NXS27 TP	27	28	MDO1
NXS29 TP (Note 3)	29	30	MDO0
+V	31	32	EVTO*
+V	33	34	MCKO
NXS35 TP (Note 3)	35	36	MSEO1*
B_VSTBY	37	38	MSEO0*

#### Notes:

- 1) B\_... signals are buffered.
- 2) NXSxx TP signals are not connected to the MPC5553 and provide a Test Pad on the board.
- 3) NXSxx signal TP is also connected to the ROBUST Nexus connector.
- 4) Signals followed by a “\*” symbol are active logic low.



## ROBUST Port

The ROBUST port connector location is provided for user expansion. This port provides the ROBUST Nexus 51 pin location that applies the GLENAIR MR7580-51P2BNU connector.

### ROBUST Port

Pin #	Signal	Pin #	Signal	Pin #	Signal
1	+V	19	MDO0	36	GND
2	+V	20	GND	37	MDO4
3	B_VSTBY1	21	MCKO	38	GND
4	NXS35 TP	22	GND	39	MDO5
5	TDO	23	EVTO*	40	GND
6	B_RDY*	24	GND	41	MDO6
7	B_RESET*	25	MSEO0*	42	GND
8	B_+3.3V	26	MDO9	43	MDO7
9	B_EVTI*	27	MDO1	44	GND
10	GND	28	GND	45	MDO8
11	B_JCOMP	29	MDO2	46	GND
12	GND	30	GND	47	MDO10
13	B_TMS	31	MDO3	48	GND
14	GND	32	GND	49	MDO11
15	B_TDI	33	NXS29 TP	50	GND
16	GND	34	GND	51	JP1 pin 2
17	B_TCK	35	MSEO1*		
18	GND				

Notes:

- 1) NXS29 and NXS35 signals are also connected to the NEXUS connector.
- 2) Signals followed by a "\*" symbol are active logic low.

### JP1 Option

JP1 provides signal selection for the Robust Nexus connector pin 51. Position 1-2 provides the BOOTCFG1 signal and position 2-3 provides the ERSTOUT\* signal.

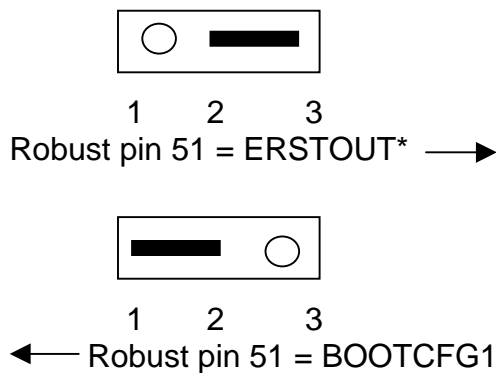

# MPC5553 I/O HEADER RING

MPC5553 I/O signals are provided by the I/O header ring. The header ring consists of .1 inch grid pins organized in 4 rows for each side of the MPC5553 device. Each row reflects the corresponding location of the MPC5553 device BGA package ball ring. Signals indicated are the EVB board primary function.

## A1 – AF4 HEADER

PIN	SIGNAL	PIN	SIGNAL	PIN	SIGNAL	PIN	SIGNAL
A1	GND	A2	VSTBY	A3	AN37	A4	AN11
B1	VDD	B2	GND	B3	AN36	B4	AN39
C1	3.3V	C2	VDD	C3	GND	C4	AN8
D1	eTPU_A30	D2	eTPU_A31	D3	VDD	D4	GND
E1	eTPU_A28	E2	eTPU_A29	E3	5V	E4	VDD
F1	eTPU_A24	F2	eTPU_A27	F3	eTPU_A26	F4	5V
G1	eTPU_A23	G2	eTPU_A22	G3	eTPU_A25	G4	eTPU_A21
H1	eTPU_A20	H2	eTPU_A19	H3	eTPU_A18	H4	eTPU_A17
J1	eTPU_A16	J2	eTPU_A15	J3	eTPU_A14	J4	eTPU_A13
K1	eTPU_A12	K2	eTPU_A11	K3	eTPU_A10	K4	eTPU_A9
L1	eTPU_A8	L2	eTPU_A7	L3	eTPU_A6	L4	eTPU_A5
M1	eTPU_A4	M2	eTPU_A3	M3	eTPU_A2	M4	eTPU_A1
N1	BDIP*	N2	TEA*	N3	eTPU_A0	N4	TCRCLK_A
P1	CS3*	P2	CS2*	P3	CS1*	P4	CS0*
R1	WE3*	R2	WE2*	R3	WE1*	R4	WE0*
T1	3.3V	T2	TSIZ0	T3	RD_WR	T4	3.3V
U1	A16	U2	TSIZ1	U3	TA*	U4	3.3V
V1	A18	V2	A17	V3	TS*	V4	A8
W1	A20	W2	A19	W3	A9	W4	A10
Y1	A22	Y2	A21	Y3	A11	Y4	3.3V
AA1	A24	AA2	A23	AA3	A13	AA4	A12
AB1	3.3V	AB2	A25	AB3	A15	AB4	A14
AC1	A26	AC2	A27	AC3	A31	AC4	GND
AD1	A28	AD2	A30	AD3	GND	AD4	VDD
AE1	A29	AE2	GND	AE3	VDD	AE4	CRS
AF1	GND	AF2	VDD	AF3	TX_CLK	AF4	TX_ER

## A22 – D5 HEADER

PIN	SIGNAL	PIN	SIGNAL	PIN	SIGNAL	PIN	SIGNAL
A22	MDO11	B22	MDO7	C22	MDO3	D22	5V
A21	GPIO205	B21	MDO10	C21	MDO6	D21	MDO2
A20	x	B20	x	C20	MDO9	D20	MDO5
A19	x	B19	x	C19	x	D19	x
A18	x	B18	x	C18	x	D18	x
A17	x	B17	x	C17	x	D17	x
A16	ETRIG1	B16	ETRIG0	C16	x	D16	x
A15	AN15	B15	AN14	C15	AN13	D15	AN12
A14	VSSA	B14	VSSA	C14	VDDA0	D14	5V
A13	AN35	B13	AN32	C13	AN33	D13	AN34
A12	AN28	B12	AN31	C12	AN30	D12	AN29
A11	AN27	B11	AN26	C11	AN25	D11	AN24
A10	AN23	B10	AN22	C10	VRL	D10	AN6_DAN3+
A9	VRH	B9	x	C9	AN7_DAN3-	D9	AN2_DAN1+
A8	AN5_AND2-	B8	AN4_AND2+	C8	AN3_DAN1-	D8	AN18
A7	AN1_AND0-	B7	AN0_AND0+	C7	AN21	D7	AN10
A6	AN16	B6	AN20	C6	VSSA	D6	AN9
A5	VDDA1	B5	AN19	C5	AN17	D5	AN38

## A23– AF26 HEADER

PIN	SIGNAL	PIN	SIGNAL	PIN	SIGNAL	PIN	SIGNAL
A23	MDO8	A24	VDD	A25	3.3V	A26	GND
B23	MDO4	B24	MDO0	B25	GND	B26	3.3V
C23	MDO1	C24	GND	C25	3.3V	C26	VDD
D23	GND	D24	3.3V	D25	TCK	D26	TDI
E23	3.3V	E24	TMS	E25	TDO	E26	TEST*
F23	MSEO0*	F24	JCOMP	F25	EVTI*	F26	EVTO*
G23	MSEO1*	G24	MCKO	G25	GPIO204	G26	x
H23	RDY*	H24	GPIO203	H25	x	H26	x
J23	5V	J24	x	J25	x	J26	x
K23	x	K24	x	K25	x	K26	x
L23	x	L24	x	L25	x	L26	x
M23	x	M24	x	M25	x	M26	SIN_B
N23	SOUT_B	N24	PCS_B3	N25	PCS_B0	N26	PCS_B1
P23	SIN_D	P24	PCS_B4	P25	SCK_B	P26	PCS_B2
R23	PCS_B5	R24	PCS_C5	R25	PCS_C2	R26	PCS_C1
T23	PCS_B2	T24	PCS_D2	T25	SCK_D	T26	5V
U23	SOUT_D	U24	TXDA	U25	PCS_B3	U26	3.3V
V23	CNTX_C	V24	RXDA	V25	RSTOUT*	V26	RSTCFG*
W23	RXDB	W24	CNRX_C	W25	TXDB	W26	RESET*
Y23	WKPCFG	Y24	BOOTCFG1	Y25	GND	Y26	GND
AA23	5V	AA24	PLLCFG1	AA25	BOOTCFG0	AA26	x (EXTAL)
AB23	VDD	AB24	x (VRCCTL)	AB25	PLLCFG0	AB26	x (XTAL)
AC23	GND	AC24	VDD	AC25	VRC33	AC26	x (VDDSYN)
AD23	NC2	AD24	GND	AD25	VDD	AD26	3.3V
AE23	3.3V	AE24	CLKOUT	AE25	GND	AE26	VDD
AF23	PCS_C4	AF24	3.3V	AF25	ENGCLK	AF26	GND

## AC22– AF5 HEADER

PIN	SIGNAL	PIN	SIGNAL	PIN	SIGNAL	PIN	SIGNAL
AC22	NC11	AD22	3.3V	AE22	CNRX_A	AF22	PCS_C3
AC21	3.3V	AD21	CNTX_A	AE21	EMIOS23	AF21	EMIOS20
AC20	5V	AD20	EMIOS22	AE20	EMIOS19	AF20	EMIOS18
AC19	EMIOS21	AD19	EMIOS17	AE19	EMIOS16	AF19	EMIOS14
AC18	EMIOS12	AD18	EMIOS15	AE18	EMIOS13	AF18	EMIOS11
AC17	EMIOS8	AD17	EMIOS10	AE17	EMIOS9	AF17	EMIOS7
AC16	EMIOS2	AD16	EMIOS6	AE16	EMIOS5	AF16	EMIOS4
AC15	D14	AD15	EMIOS3	AE15	EMIOS1	AF15	EMOS0
AC14	D12	AD14	D15	AE14	MDIO	AF14	BB*
AC13	3.3V	AD13	D13	AE13	MDC	AF13	D7
AC12	D10	AD12	D11	AE12	OE*	AF12	D5
AC11	D8	AD11	D9	AE11	D6	AF11	3.3V
AC10	RXD3	AD10	GPIO207	AE10	D4	AF10	D3
AC9	RXD2	AD9	3.3V	AE9	D2	AF9	D1
AC8	3.3V	AD8	RXD1	AE8	D0	AF8	GPIO206
AC7	TXD1	AD7	TXD2	AE7	TXD3	AF7	RXD0
AC6	TX_EN	AD6	RX_DV	AE6	RX_ER	AF6	TXD0
AC5	VDD	AD5	COL	AE5	RX_CLK	AF5	3.3V

Note: Indicated as AF22 / AF5 on EVB board.