

Approvals		Date	File	
Drawn: GLG		113009	DEMO9S12XHY256	
Checked: DSR	113009	Size: C	Document Number: DOC-0509-030	Rev: B
Finish		Date: Tuesday, March 30, 2010	Sheet 1 of 3	

SHEET 1 PORT S  
 SHEET 1 CONTROL SIGNAL  
 SHEET 1 ANALOG PORT  
 SHEET 1 PORT R

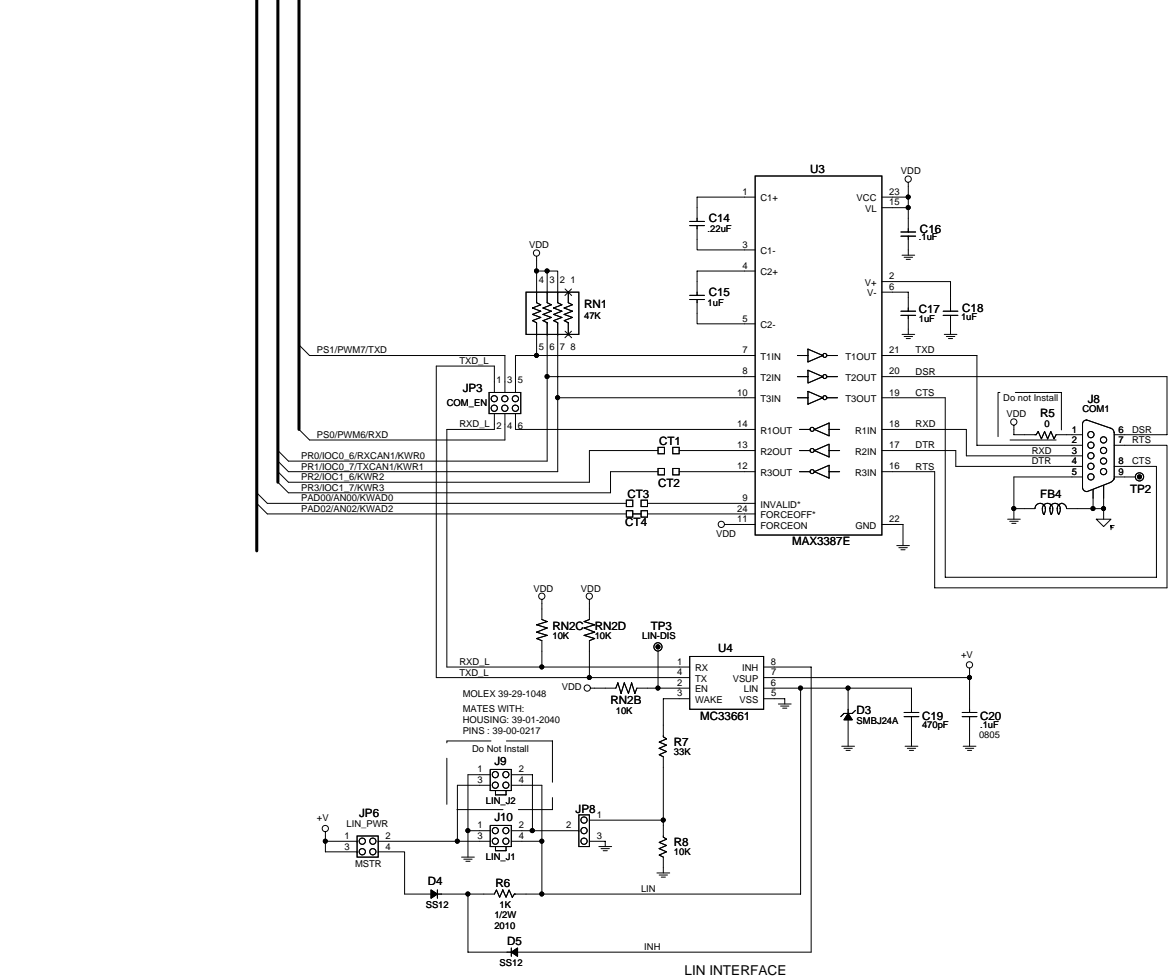

LIN INTERFACE

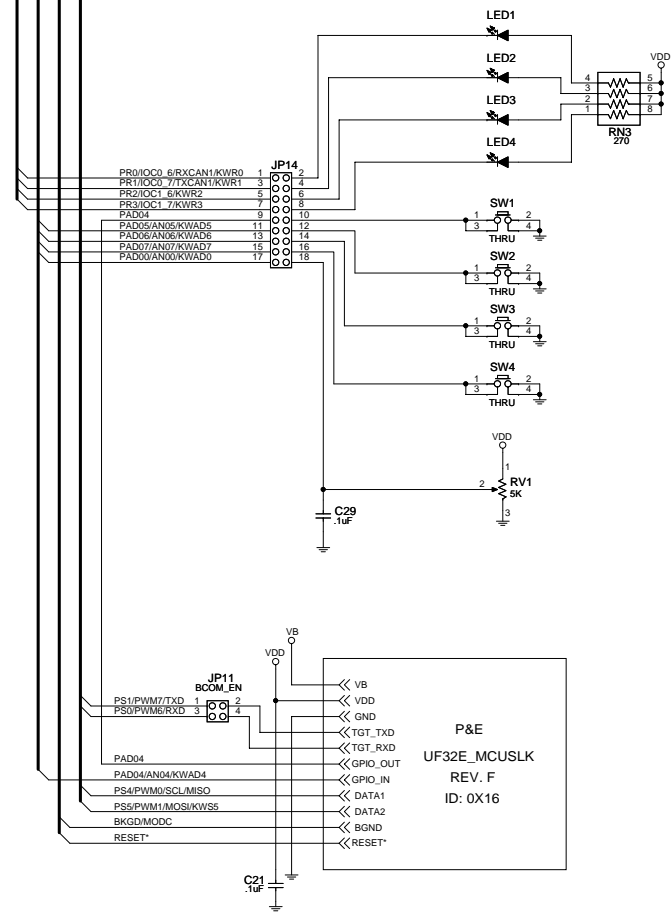
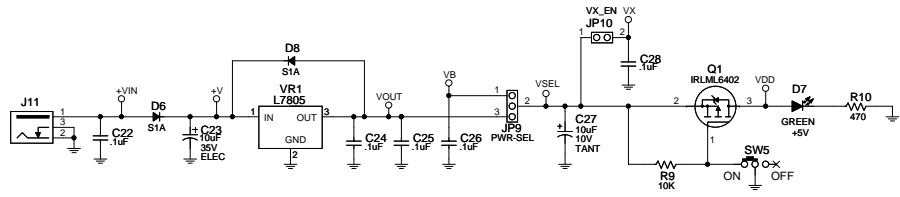

NOTE:  
 10K OHM PULL-UPS  
 APPLIED ON RESET\* &  
 BKGD INSIDE P&E BLOCK

<table border="1"> <tr> <th>Approvals</th> <th>Date</th> </tr> <tr> <td>Drawn GLG</td> <td>113009</td> </tr> <tr> <td>Checked DSR</td> <td>113009</td> </tr> <tr> <td>Finish</td> <td></td> </tr> </table>	Approvals	Date	Drawn GLG	113009	Checked DSR	113009	Finish		<table border="1"> <tr> <td colspan="2">File</td> </tr> <tr> <td colspan="2">DEMO9S12XHY256</td> </tr> <tr> <td>Size C</td> <td>Document Number</td> </tr> <tr> <td></td> <td>DOC-0509-030</td> </tr> <tr> <td>Date: Tuesday, March 30, 2010</td> <td>Sheet 2 of 3</td> </tr> </table>	File		DEMO9S12XHY256		Size C	Document Number		DOC-0509-030	Date: Tuesday, March 30, 2010	Sheet 2 of 3
Approvals	Date																		
Drawn GLG	113009																		
Checked DSR	113009																		
Finish																			
File																			
DEMO9S12XHY256																			
Size C	Document Number																		
	DOC-0509-030																		
Date: Tuesday, March 30, 2010	Sheet 2 of 3																		

SHEET2

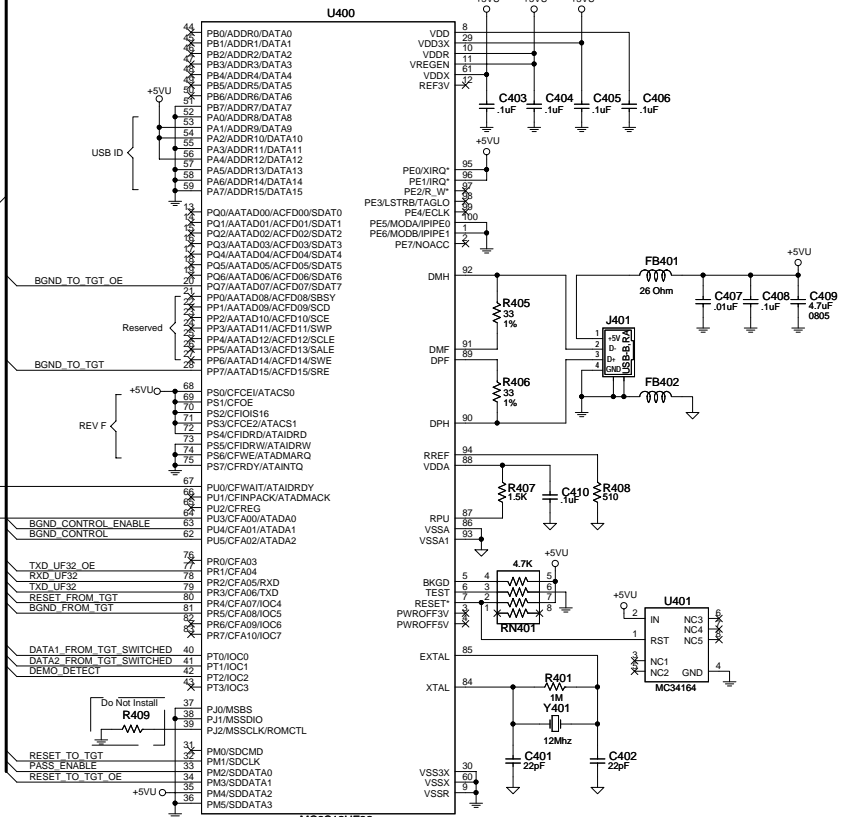
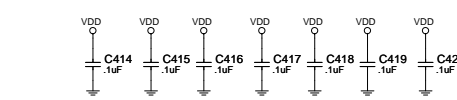
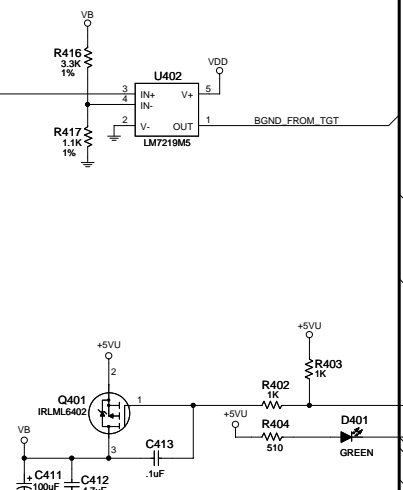
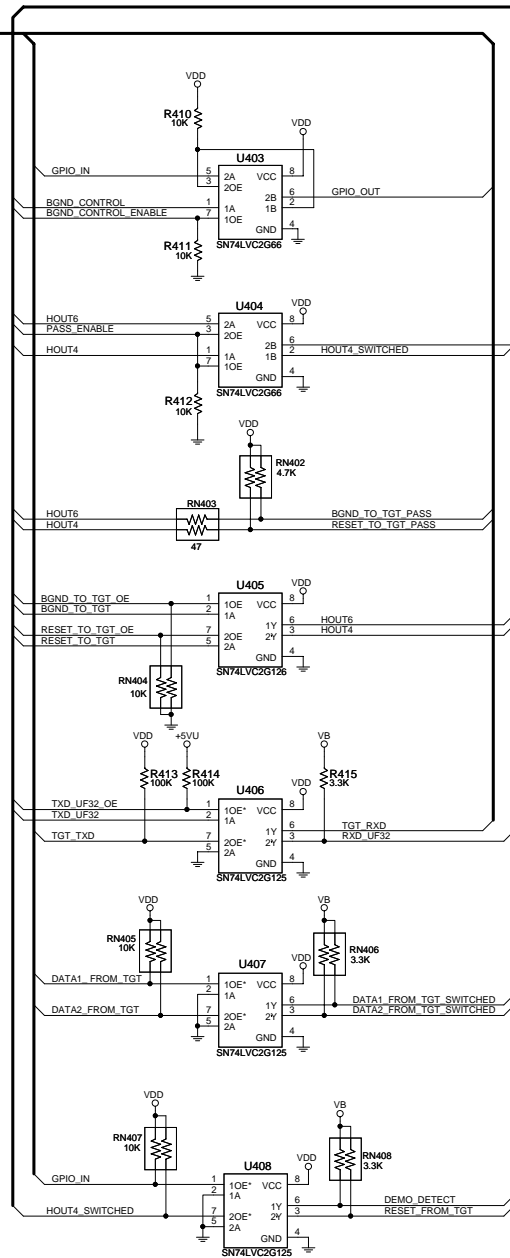

Approvals		Date	File	
Drawn	GLG	113009	DEMO9S12XHY256	
Checked	DSR	113009	Size	Document Number
Finish			C	DOC-0509-030
		Date:	Tuesday, March 30, 2010	Sheet 3 of 3